



Catalis

Packaging Technologies Pvt. Ltd.



➤ C 150

Horizontal wrapping machine

- For packing products from wide range including bakery, snacks, prepared foods and many other food and non-food items
- 3 Servo machine: servo at end-seal, pulling and in-feed
- Highly reliable and flexible
- Touch screen based easy machine interface
- Superior seal quality

Catalis Packaging Technologies Pvt. Ltd.: 216, GIDC Makarpura, Vadodara-390010.

Mobile: +91 9825235931 | Email: info@catalispackaging.com | Web: www.catalispackaging.com



Catalis

Packaging Technologies Pvt. Ltd.

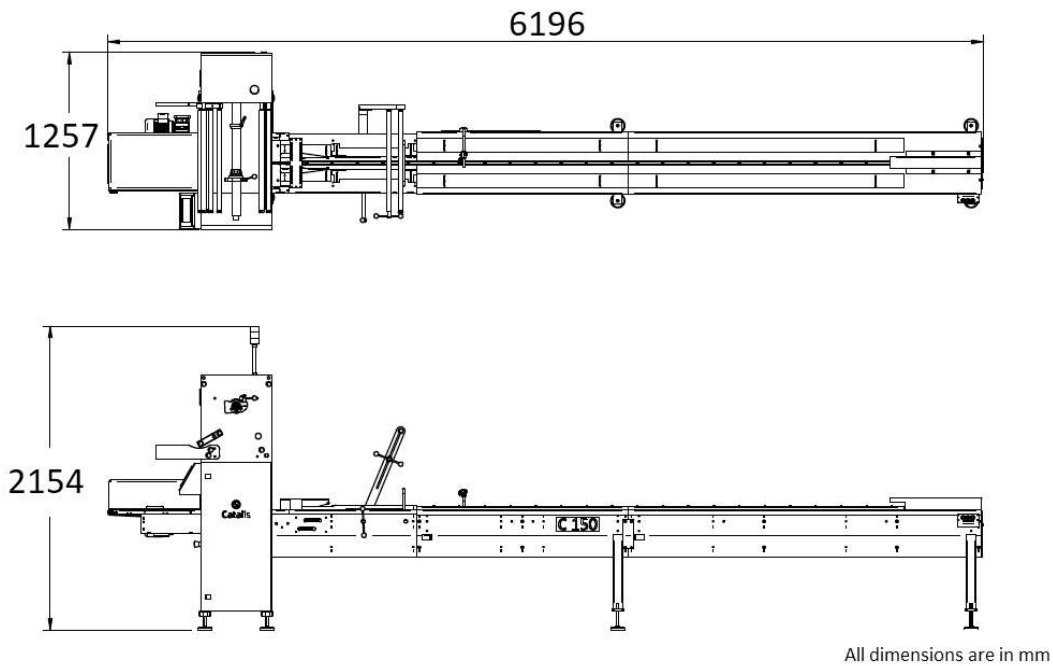

Specifications:

| MODEL | C 150 |
|--------------------------------|-----------------------------------|
| Speed | 150 bags/min - 28 m/min |
| Maximum Flm Width | 650 mm |
| Maximum Roll Diameter | 400 mm |
| Maximum Roll Weight | 35 kg |
| Jaw Diameter | 120 mm / 150 mm / 180 mm |
| Maximum Bag Length [2 Jaw Set] | 185 mm / 235 mm / 280 mm |
| Maximum Bag Length [1 Jaw Set] | 375 mm / 470 mm / 560 mm |
| Product Length | 80 mm to 455 mm |
| Product Width | 20 mm to 250 mm |
| Product Height | 8 mm to 105 mm |
| Power Supply Voltage | 3 Phase, 415 VAC \pm 10%, 50 Hz |
| Air Pressure | 6 bar |
| Operational Temperature | 0-40°C RH30-70% Non-Condensing |

All rights reserved. The information contain herein may be changed without prior notice.

Catalis Packaging Technologies Pvt. Ltd.: 216, GIDC Makarpura, Vadodara-390010.

Mobile: +91 9825235931

Email: info@catalispackaging.com

Web: www.catalispackaging.com